

PHONE BOOTH

As standard, the Phone Booth comes upholstered in a choice of certified acoustic and fire retardant felt.

For the price you'll also benefit from integrated dimmable LED lighting, mark resistant castors and ventilation unit as well as power & data in the form of mains and USB outlets.

A purpose built stool is also available as an optional extra.

DIMENSIONS IN MM

WIDTH 1450/1050

DEPTH 1180

HEIGHT 2300

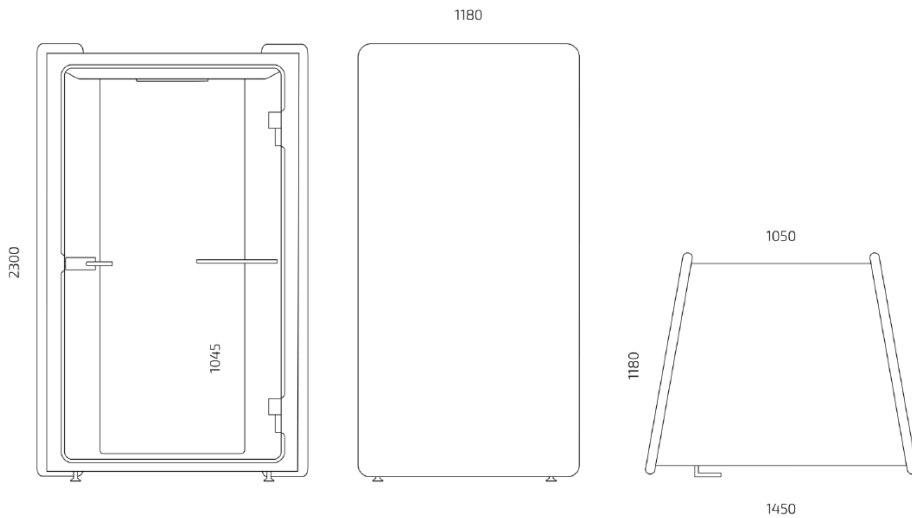

In association with:

intuit
BY SOFTREND

PHONE BOOTH



PHONE BOOTH

UPHOLSTERY OPTIONS

STANDARD OUTSIDE SHELL FABRIC



STANDARD INSIDE WALL PANEL COVERS

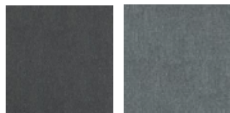

STANDARD FLOOR COVERS

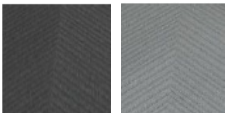

PHONE BOOTH

Technical details:

PACKAGED (1 PALLETIZED CRATE)

LENGTH: 240 CM
HEIGHT: 146 CM
WIDTH: 80 CM

WEIGHT

BOOTH: 419 KG
PACKAGED BOOTH: 470 KG

POWER

MAINS SUPPLY: 230V, 50HZ, MAX 10A
CONSUMPTION WHEN IN USE: 10W UP TO 130W (AT FULL VENT AND MAX LIGHT-
NING)
INTERNAL FUSE: C10, RCD 30MA

LIGHTING UNIT

POWER USAGE: 24-49W
INPUT: 230V / 50-60HZ
LUMEN OUTPUT: 1200-8000 LUMEN
COLOUR TEMPERATURE: 3000/4000K
COLOUR RENDERING INDEX: >80
DIMMER: YES

OUTPUT

TABLE SOCKET: 230V, 50HZ, MAX 8A
OPTIONAL: USB CHARGER TYPE A AND C, MAX 5A

VENTILATION UNIT

AIRFLOW RATE WHEN OCCUPIED: 40L/S
WORKSMAX WHEN OCCUPIED.
AIRFLOW RATE STAND-BY MODE, AFTER 5 MINS NO OCCUPANCY: 27L/S
POWERUSAGE: MAX 2W; INPUT 12VDC

CASTORS

Ø 60 MM
W 40 MM
NON-MARKING AND NON-STAINING

ACOUSTICS

31,1 DECIBEL SOUND REDUCTION